

STABILA LE 50 laser distance measurer



With it, you can measure faster, more accurately and more comfortably.

- One man using the STABILA LE 50 can measure quicker and more accurately than two men using a traditional measuring instrument. And all without twisting and turning.
- At the push of a button, the LE 50 calculates the geometric values from the length measurement.
- One-hand operation – simple menu guide.



The STABILA LE 50 laser distance measurer provides:

- Range 0.05–100 m (0.16–325 ft)
- Measurement accuracy: typ. +/- 3 mm (+/- 0.12 inch)
- Distance, area and volume measurement
- Changeover m/ft: 7 different measurement units (metric and inch/foot)
- 19 stacks (memorisation of the most recent values)
- Sequential measurements (addition) and intermediate distances (subtraction)
- Continuous measurement (tracking) with min/max display
- Reference change-over: measurement from the equipment's front and/or rear edge
 - Illuminated display
 - Small and light – fits into a shirt pocket

Where does your new LE 50 pay for itself?

- When measuring: rooms, windows, façades, surface areas, walls, ceiling heights, properties ...
- When creating plans, offers, invoices.



Measure up to **100 m**

How does a laser distance measurer operate?
 STABILA Laser distance measurers consist of the main laser components, the receiver and the evaluation and display unit. The distance measurement is based on measuring the phase difference of modulated laser light: i. e., a laser beam is emitted in the direction of the target, reflected there and received back at measuring instrument. The distance is calculated from the phase difference measured.

STABILA LE 200 laser distance measurer

For heavy-duty use: The STABILA LE 200 laser distance measurer.

- Range 0.05–200 m (0.16–650 ft)
- Measurement accuracy: typ. +/- 2 mm (+/- 0.08 inch)
- Distance, area and volume measurement
- Integral target optics with double magnification (captures the measurement point at great distances)
- Calculation with measured and calculated values
- Changeover m/ft: 8 different measurement units (metric and inch/foot)
- 15 freely usable memory constants
- 15 stacks (memorisation of the most recent values)
- Sequential measurements (addition) and intermediate distances (subtraction)
- Continuous measurement (tracking) with min/max display



Multi-function flip-out end piece for lacing in corners.

- Pythagoras function
- Trapezoid function
- Autotimer function
- Reference change-over (the unit automatically recognises the measurement unit when the multi-function flip-out end piece is unfolded)
- Measurement with added tolerances
- Threaded photo tripod
- Multi-function flip-out end piece for placing in corners and on edges
- Illuminated display



Integral target optics with double magnification.



Reference change-over for measurement from the tripod.

Measure up to **200 m**



STABILA spirit levels



STABILA folding rules



STABILA laser measuring equipment



STABILA tape measures



STABILA laser accessories



STABILA straight-edges

NEW

Full details of STABILA's lasers, spirit levels, folding rules, measuring tapes, tripods and levels. 84 pages. Free of charge to the specialist trade.



You will find detailed product information on the Web at www.stabila.de. Our Technical Hotline is there to assist you in all your questions regarding product selection and use: telephone +49-6346-309-0. Or, of course, you can always e-mail us at info@stabila.de.

LE 50

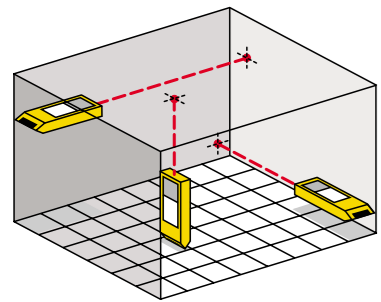

Measuring lengths, surfaces and volumes.

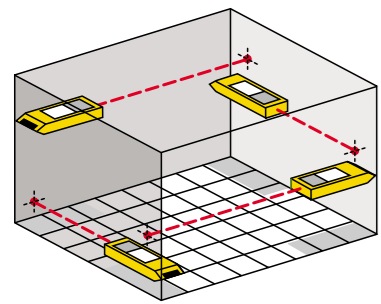

Determine incremental dimensions.

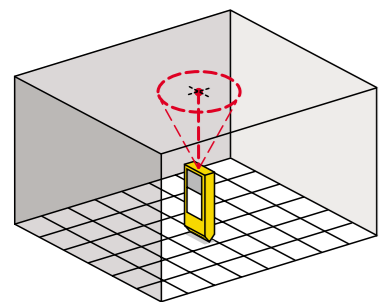

The minimum tracking is used to measure the shortest distance between two points (Minimum tracking).

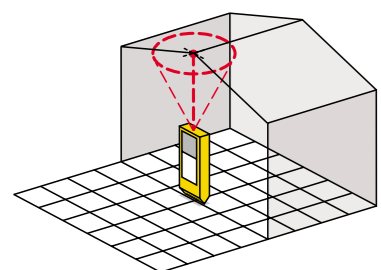

Tracking to measure maximum diagonal, for instance (Maximum tracking).

LE 200

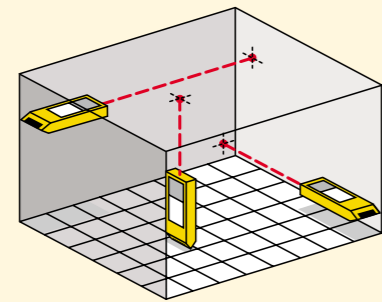

Measuring lengths, surfaces and volumes.

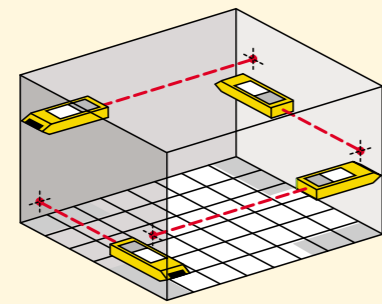

Determine incremental dimensions.

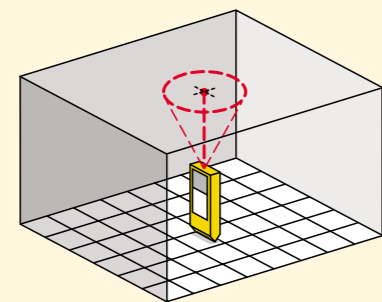

The minimum tracking is used to measure the shortest distance between two points (Minimum tracking).

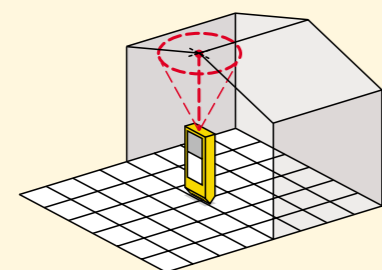

Tracking to measure maximum diagonal, for instance (Maximum tracking).

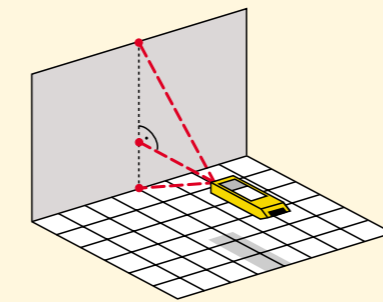

The Pythagoras function is used, for instance, to determine a height using two or three measurement points.

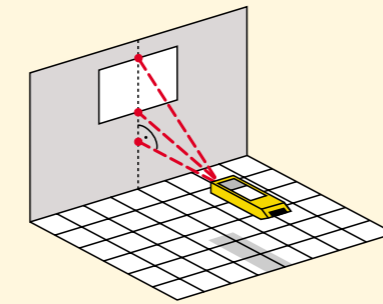

Pythagoras 2: Indirect measurement of an intermediate distance (e.g. window heights).

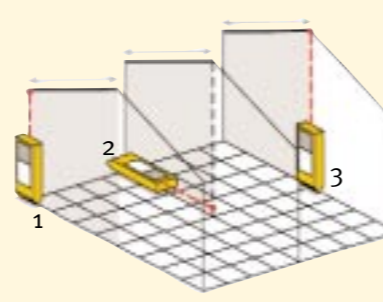

Trapezoid measurement: this enables sloping, not directly accessible stretches to be measured.

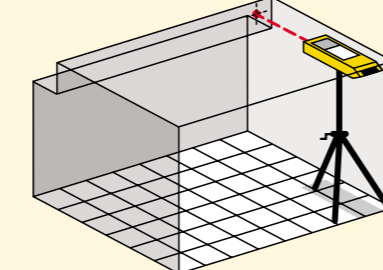

Autotimer function: e.g. for blur-free measurement from the tripod.

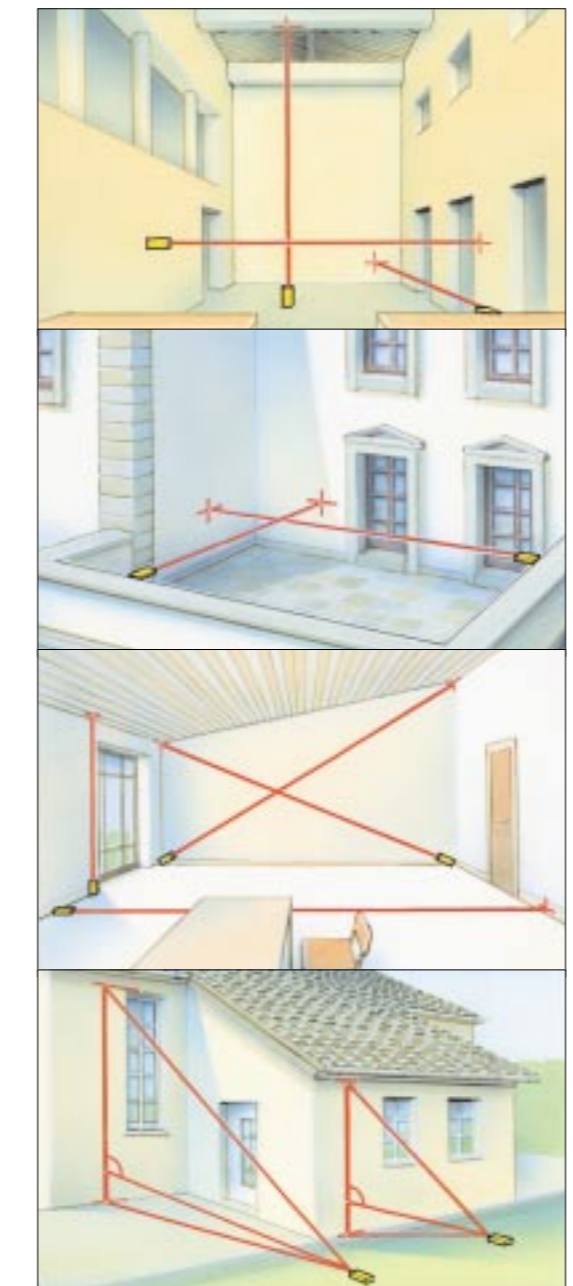

LE 50

Measurement accuracy	typ. ± 3 mm (+/- 0.12 inch)
Smallest unit displayed	1 mm
Range	0.05–100 m (0.16–325 ft)
Ø of laser point (by distance)	6 / 30 / 60 mm (10 / 50 / 100 m)
Light	•
Multi-line display	•
Multi-functional end-piece	—
Automatic off-switch	—
Pocket calculator	•
Tracking	•
Constants	0 values
Memory	19 values
Minimum/maximum tracking	•
Pythagoras function	—
Weights and measures	135 x 49 x 31 mm, 160 g

Laser class 2	Output	Laser wavelength	Accuracy	Range	Battery life	Batteries (incl. case)
	< 1 mW	635 nm	typ. ± 3 mm	0.05 m to 100 m	Up to 5,000 measurements	2 x AAA
Type	LE 50	Art.No.	16205	EAN	4005069162054	

If the beam of a Class 2 laser should accidentally enter the eye of an observer for a short period, the eye is protected by the reflex action of closing the eye-lid and/or looking away. These lasers may therefore be used without any further protective measures. However, you should not look directly into the laser beam.

LE 200

Measurement accuracy	typ. ± 2 mm (+/- 0.08 inch)
Smallest unit displayed	1 mm
Range	0.05–200 m (0.16–650 ft)
Ø of laser point (by distance)	6 / 30 / 60 mm (10 / 50 / 100 m)
Light	•
Multi-line display	•
Multi-functional end-piece	•
Automatic off-switch	•
Pocket calculator	•
Tracking	•
Constants	15 values
Memory	15 values
Minimum/maximum tracking	•
Pythagoras function	•
Weights and measures	148 x 66 x 36 mm, 310 g

Laser class 2	Output	Laser wavelength	Accuracy	Range	Battery life	Batteries (incl. case)
	< 1 mW	635 nm	typ. ± 2 mm	0.05 m to 200 m	Up to 10,000 measurements	2 x AA
Type	LE 200	Art.No.	16203	EAN	4005069162030	

If the beam of a Class 2 laser should accidentally enter the eye of an observer for a short period, the eye is protected by the reflex action of closing the eye-lid and/or looking away. These lasers may therefore be used without any further protective measures. However, you should not look directly into the laser beam.

STABILA laser distance measurer LE 50



LE 50 set: LE 50 laser distance measurer, holster, carrying case.

STABILA laser distance measurer LE 200



LE 200 set: LE 200 laser distance measurer, holster, carrying case.

Useful accessories

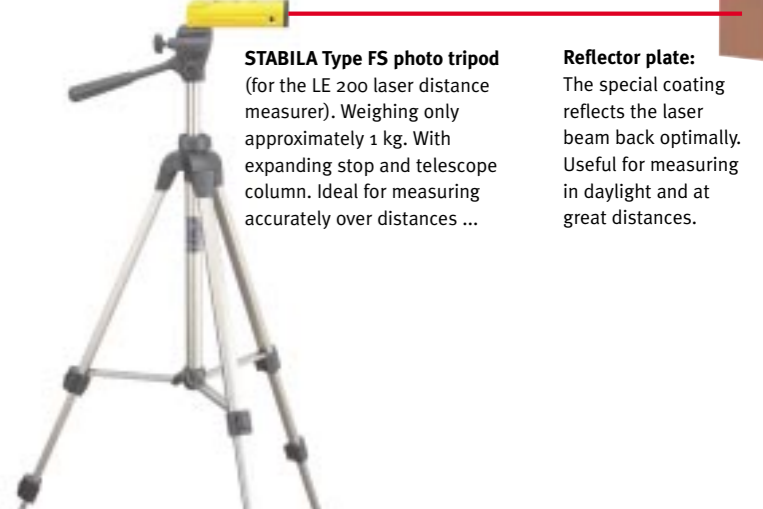

STABILA Type FS photo tripod (for the LE 200 laser distance measurer). Weighing only approximately 1 kg. With expanding stop and telescope column. Ideal for measuring accurately over distances ...

Reflector plate: The special coating reflects the laser beam back optimally. Useful for measuring in daylight and at great distances.