

OPERATING INSTRUCTIONS

TECNIX 590 (C)

MOISTURE METER

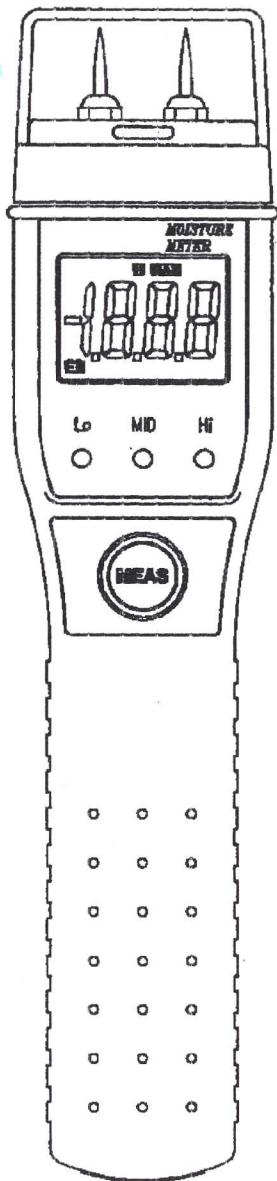

INTRODUCTION

The model 690 moisture meter enables to measure the wood moisture content from 8 % to 28 %.

This instrument is a portable easy use 3 1/2 digit, compact-sized digital moisture content meter designed for simple one hand operation.

Remove the protective cover expose two pins then press "MEAS" button to measure the wood's moisture content.

To take a reading, align the contact pins parallel to the grain and push them to their full penetration into the wood, if possible.

Insulated pins read only at the tip and can be driven to the desired depth.

PRECAUTION

To minimize the effect of "Static Electricity":

1. Drive the electrode pins into the wood with the meter turned off, and then turn the meter on when you are ready to take the reading.
2. After driving the pins, place your hand next to them on each side of electrode to help discharge the static from the board.
3. Passing a damp cloth over the board's surface to pick up any static charges before driving the pins.

How to use

1. Remove the protective cover and plug two pins into a wood.
2. Put two pins for at least 4 ~ 5mm into wood then press "MEAS" button to measure the wood's moisture content.
3. When the meter power off please press "MEAS" again to resume the meter.
4. Continuity press "MEAS" button to continuous measure wood's moisture content.
5. Reading above 28 % increasing levels of high moisture. They are not percent moisture content.
6. Continuous display of "E" indicates that battery should be replaced.

SAFETY INFORMATION

When you are not use the meter make sure the cap was closed to avoid get hurt.

Replace the contact pins when they are damaged.

WARNING

To avoid damage to instrument, remove dead battery immediately.

Remove battery when Low Batt light displayed.
Remove power from circuit under test.

WARNING

To avoid electrical shock remove test leads before opening case or battery cover.

Do not operate with battery cover open.

Light indicate

GREEN:

"Air-dry" conditions. Decay impossible.

YELLOW:

Slightly in excess of normal. Investigate further.

RED:

Excess moisture. Decay inevitable.

OPERATING INSTRUCTIONS

Push Button

MEAS Button

Press "MEAS" button to measure the moisture content.

SPECIFICATIONS

GENERAL

Display:

3 1/2 digit liquid crystal display (LCD).

Low battery indication:

The "E" is displayed when the battery voltage drops below the operating level.

Auto power off:

15 seconds approx.

Operating Environment:

32°F to 122°F (0°C to 50°C) < 80% relative humidity.

Storage Temperature:

-4°F to 140°F (-20°C to 60°C), 0 to 80% R.H. with battery removed from meter.

Battery:

4 pcs 1.5V (AAA size) UM-4 R03.

Battery Life:

30 hours (continuity).

(No measurable current draw when power off.)

Dimensions:

190mm(H) x 44 mm(W) x 40 mm(D).

Weight:

approx: 170g including battery.

ELECTRICAL

Range: 8% ~ 28%

Accuracy: ±2.0%.

Stated accuracy at 23°C ±5°C, < 75% relative humidity.

MAINTENANCE

Battery Replacement

1. When "E" appears on the LCD display.
2. Turn off the meter.
3. Remove the screw at the middle of the back side of the meter, and slide the back cover off.
4. Remove batteries from the compartment.
5. Install 4 pcs of new AAA 1.5V batteries (UM-4 R03), Alkaline type is recommended.
6. Slide battery cover back to its position and fasten the screw.

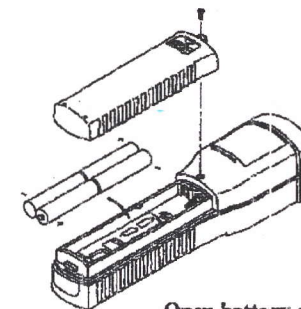

Open battery cover

Cleaning

Periodically wipe the case with a damp cloth and detergent, do not use abrasives or solvents.