

STABILA®



...sets standards



- | | | | |
|------------|-------------------------|------------|----------------------------|
| D | Bedienungsanleitung | TR | Kullanma K lavuzu |
| GB | Operating instructions | CZ | Návod k pou·ití |
| F | Mode d'emploi | PL | Instrukcja obs³ugi |
| I | Istruzioni per l'uso | SLO | Navodilo za uporabo |
| E | Manual de Instrucciones | H | Használati utasítás |
| NL | Gebruiksaanwijzing | GR | Οδηγός χειρισμού |
| P | Manual de instruções | RUS | Инструкция по обслуживанию |
| N | Brukerveiledning | EST | Kasutusjuhend |
| FIN | Käyttöohje | J | 取扱説明 |
| DK | Betjeningsvejledning | KOR | 사용 설명서 |
| S | Bruksanvisning | CHN | 操作说明书 |

Operating instructions

Thank you for your confidence in our products. By purchasing a STABILA PointerMan you have obtained a high-quality, easy to use measuring tool that will make many of your manual levelling and alignment tasks much easier and provide increased accuracy. We wish you much enjoyment from your purchase.

We have tried to explain the unit's handling and operation as clearly and comprehensively as possible. Should you still have any questions, however, you can receive advice over the telephone at any time by dialling the following number:

0049-6346-3090

Main elements

- (1) Horizontal vials
- (2) Vertical vial
- (3) On/Off switch
- (4) Adjustment screws
- (5) Fixed base
- (6) Penta prism mounting
- (7) Battery cover
- (8) Laser unit
- (9) Base plate

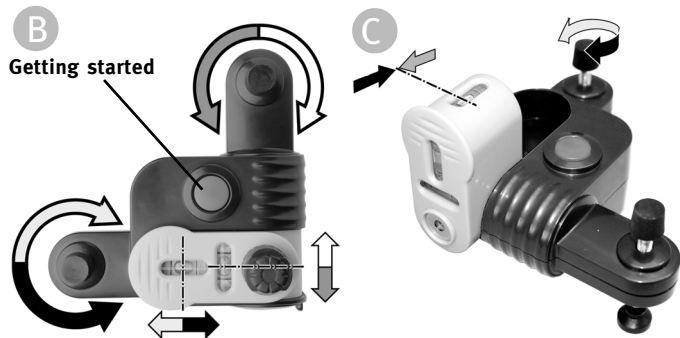

NB:

This is a class 2 laser and can be used without any protective measures. However, you should not look directly into the laser and should not let children play with the unit!

Goggles that are available for these units are not safety goggles. They are only there to enable you to see the laser beam more clearly.



EN 60825-1: 03-10

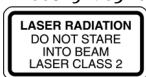

Recycling programme for our EU customers:

In accordance with the WEEE regulations, STABILA provides a disposal programme for electronic products at the end of their service life.

For more details, please contact:

[www.STABILA.de / Recycling](http://www.STABILA.de/Recycling)

or:

0049 / 6346 / 309-0



Function

Using the two adjustment screws (4), you should align the two horizontal vials so that the bubbles in the vials are between the rings.

B

Establishing verticals

Once both levels have been adjusted, the laser beam forms the vertical extension of the unit's fixed base, enabling points to be recorded very simply or alignments to be checked.

Levelling

Mounting the deflection prism deflects the vertical beam by precisely 90°. In this way, horizontal areas can be marked out by rotating the prism.

Marking out vertical surfaces (vertical levelling)

Create rectangular areas on horizontal surfaces. There are many possible applications, which can be classified under two basic methods. Place the unit on the flattest surface possible. Set the unit so that the PointerMan's direction is aligned approximately parallel or at right angles to the wall. Adjust the legs to align vial.

C

Parallel to the wall:

1. Mark a reference line on the floor or the ceiling parallel to the wall.

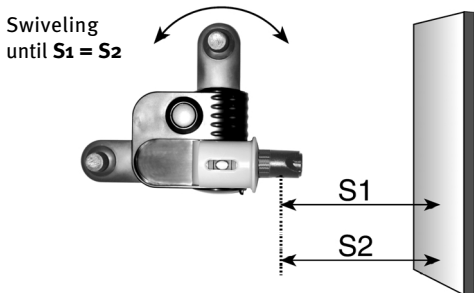

Right angles to the wall:

2. Create the reference area at right angles to the walls.

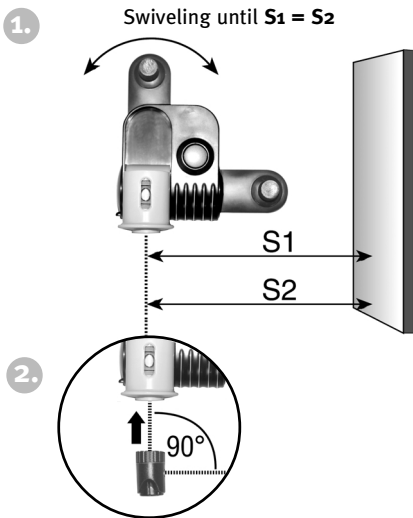

NB:

When working with the PointerMan, regularly check the vial's setting. This must be set precisely to obtain the correct measurements.

Horizontal control

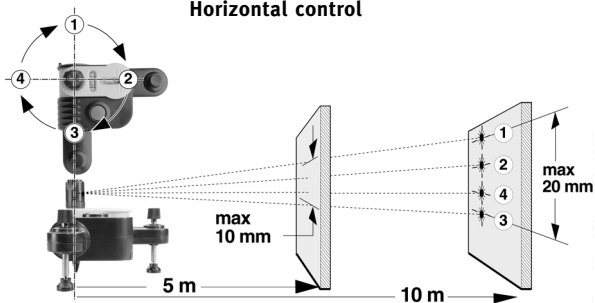

1. Place the PointerMan on a smooth, flat surface 5 or 10 m away from a wall so that one of the vials lies precisely in the longitudinal direction to the wall.
2. Align the unit by adjusting the vials. Align the laser beam on the wall by turning the Penta prism. Mark the centre of the beam on the wall – measurement 1 (Point (1)). The diameter of the beam alters over distance so the centre of the beam should always be used for marking purposes.
3. Turn the laser 90° without altering the height of the laser. Align the unit by adjusting the vials. Turn the deflection to the wall again in the area of measurement point 1 and mark the centre of the laser beam on the wall (Point (2)).
4. Turn the laser twice again by 90° to mark Points (3) and (4).
5. Differences between the 4 control points of less than 10 mm at 5 m or 20 mm at 10 m distance from the wall are within the permissible tolerance of ± 1.0 mm/m.

Vertical control (with the laser beam horizontal)

1. Mount the laser unit on the base plate with the vertical vial (2) facing upwards and set it up on a smooth, horizontal surface directly in front of a wall (A) at a distance of $S = 5$ m or more from another wall (B).
2. Direct the laser beam against wall (A) and align the vial.
3. Mark the centre of the visible laser beam on wall (A) for Point (1).



- Turn the unit 180° on the base without altering the height of the laser.
- Align the vial and mark the centre of the laser beam on wall (B) for Point (2).
- Now place the PointerMan directly in front of wall (B).
- Direct the laser beam against wall (B) and align the vial.
- Mark the centre of the laser beam on wall (B) for Point (3), as perpendicular as possible to Point (2).
- Turn the unit 180° on the base without altering the height of the laser.
- Align the vial and mark the centre of the laser beam on the wall for Point (4).
- Measure the relevant heights of the points, either from the floor or in relation to the bottom point (which in this case will be set to 0 mm).

$$1,0 \frac{\text{mm}}{\text{m}} \geq \frac{(P_4 - P_1) - (P_3 - P_2)}{2S}$$

Changing the batteries

Slide the battery cover (7) in the direction of the arrow and insert new batteries in accordance with the symbols in the battery compartment.

2 x 1,5 V
mignoncells,
size AA, LR6

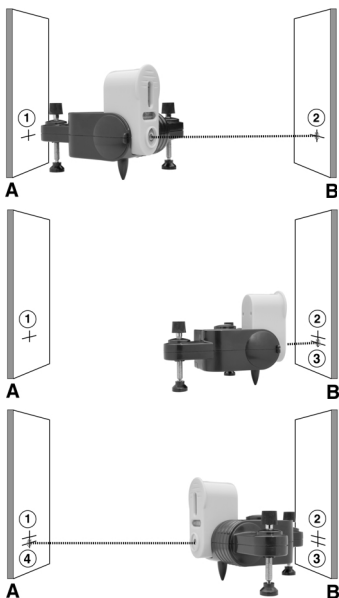

(Make sure that this is calculated with the symbols in the correct order)

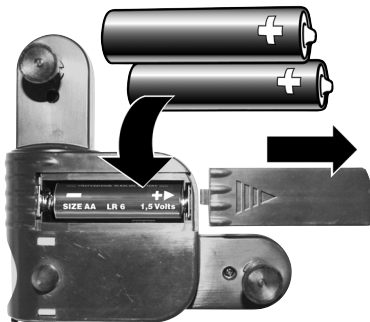

Care and maintenance

- Carefully wipe the unit dry before storing it in its protective holder (transport holder).
- Remove the batteries if the unit will not be used for a long period.
- Dirt on the laser's output lenses detract from the quality of the beam. Clean with a soft cloth and, if necessary, with glass cleaner.
- Clean the unit with a damp cloth. Do not spray or immerse the unit in water!
- Do not use solvents or thinners!

Technical data

Universal Laser:

Output:	≤ 1 mW. Class 2 laser
Levelling precision:	± 1.0 mm/m
Batteries:	2 x 1,5 V alkaline mignon cell , size AA, LR6
Battery life:	ca. 16 hours
Operating temperature range:	0 °C to +50 °C (+32 °F to +122 °F)
Storage temperature range:	-30 °C to +60 °C (-22 °F to +140 °F)
Laser wavelength:	650 nm

Technical details subject to change without notice.

Guarantee conditions

STABILA guarantees the unit's stated characteristics against any defects or faults due to material or manufacturing faults for a period of 24 months from the date of purchase. Any defects will be eliminated at our own discretion either by rectifying or replacing the unit. STABILA accepts no other claims.

No liability is accepted for any defects due to inappropriate handling (e.g. damage caused by a fall, operation using the wrong voltage or type of current, use of an inappropriate electrical source, etc.) nor any changes made to the unit by the customer or a third party.

The guarantee also does not cover normal wear and tear and any small defects that do not significantly affect the unit's operation.

Any guarantee claims should be made by filling in the guarantee form (see last page) and returning this, together with the unit, to your dealer.



STABILA Messgeräte
Gustav Ullrich GmbH
P.O. Box 13 40 / D-76851 Annweiler
Landauer Str. 45 / D-76855 Annweiler
Tel.: 00 49 (0) 63 46 / 3 09-470
Fax: 00 49 (0) 63 46 / 3 09-480
e-mail: info@stabila.de
www.stabila.de